

PGB COMMERCIAL SERIES

50 Hz

GAS/ELECTRIC PACKAGE
AIR CONDITIONER

7½, 10, AND 15 TON

COOLING CAPACITY:
90,000 TO 180,000 BTU/H
[26.4 TO 52.8 kW]

HEATING CAPACITY:
210,000 TO 245,000 BTU/H
[61.5 TO 71.8 kW]



The PGB Commercial 50 Hz gas/electric package air conditioner is designed for over/under or downflow application.

Standard Features

- Dual high-efficiency scroll compressors with internal motor protection (two-stage cooling; three compressors on 15-ton units)
- Heavy-gauge aluminized steel heat exchangers
- Power-assisted combustion
- Time delay for compressors sequence
- Fully charged systems
- High- and low-pressure controls
- Mild ambient switch
- Two independent condenser coils for two-stage operation
- Totally enclosed, permanently lubricated outdoor fan motors
- Enhanced copper tubing/aluminum fin coils
- Expansion valve evaporator coil
- Belt-driven, variable-pitch sheave permits multi-speed adjustment
- Centrifugal fan for quiet and efficient operation
- Filters provided with unit (2" [50.8mm] disposable)
- Combination redundant gas valve and regulator
- Integrated DSI ignition Control
- Operation to 0 °F (-18 °C)

Cabinet Features

- Heavy gauge zinc-coated steel cabinet with weather resistant powder-paint finish
- Galvanized steel, powder-coated drain pan with ¾" (19mm) NPT condensate connection
- Compressor grommets for vibration isolation
- Vertical discharge with removable grilles provide easy access to fans and motors
- Control box and compressors easily accessible from side access panels
- Factory wiring conveniently arranged for installing accessories
- Base rails with fork slots allow for convenient handling and added rigidity
- Built-in filter rack

Accessories

- Room thermostat
- Rooftop lift kit; Roof curb
- Low ambient control
- Economizers (horizontal and vertical)
- Manual and motorized fresh-air dampers
- Horizontal duct kit
- LP (G31 Gas) Kit
- Panel Louver Kit

PRODUCT SPECIFICATIONS

NOMENCLATURE

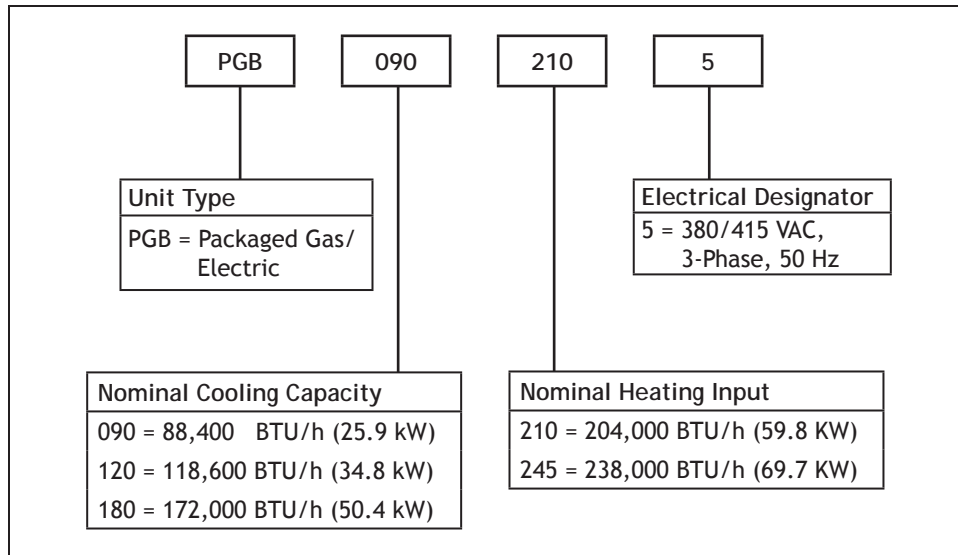

SPECIFICATIONS

	PGB090210-5	PGB120245-5	PGB180245-5
Total Cooling - BTU/h (kW)	88,400 (25.9)	118,600 (34.8)	172,000 (50.4)
Sensible Cooling - BTU/h ¹ (kW)	67,100 (19.7)	89,200 (26.1)	131,000 (38.4)
EER ²	8.9	9.7	8.5
Heating Input - BTU/h (kW)	208,000 (59.8)	238,000 (69.7)	238,000 (69.7)
Heating Output - BTU/h (kW)	162,200 (47.5)	185,600 (54.4)	185,600 (54.4)
Steady State Efficiency (Gross)	78%	78%	78%
Net Flue Efficiency	85.6%	85.6%	85.6%
Indoor Blower Quantity	2	2	2
Type	Belt	Belt	Belt
Size - D x W (mm)	12" x 12" (305 x 305)	12" x 15" (305 x 381)	12" x 15" (305 x 381)
Motor Horsepower (kW)	2 (1.49)	3 (2.24)	5 (3.73)
Indoor CFM Nominal (L/S)	3,000 (1,416)	4,000 (1,888)	5,600 (2,643)
Evaporator Coil Quantity	1	1	1
Face Area - ft ² (m ²)	9.3 (0.86)	14.0 (1.3)	14.0 (1.3)
Rows/FPI (FPM)	3/16 (630)	3/16 (630)	3/16 (630)
Tube Diameter (mm)/Material	¾" (9.5)/Copper	¾" (9.5)/Copper	¾" (9.5)/Copper
Filter Size and Quantity (mm)	(3) 25" x 25" x 2" (635 x 635 x 8.51)	(3) 16" x 25" x 2" (406 x 635 x 51) (3) 20" x 25" x 2" (508 x 635 x 51)	(3) 16" x 25" x 2" (406 x 635 x 51) (3) 20" x 25" x 2" (508 x 635 x 51)
Outdoor Fan Quantity	2	2	2
Fan Diameter (mm)	24" (610)	24" (610)	22" (559)
Motor Horsepower (kW)	1/2 (0.37)	1/2 (0.37)	1/2 (0.37)
Outdoor CFM Nominal (L/S)	4300 (2030)	6100 (2880)	7000 (3300)
Condenser Coil Quantity	1	1	1
Face Area Total - ft ² (m ²)	15.6 (1.45)	23.8 (2.21)	23.8 (2.21)
Rows/FPI (FPM)	2/21 (827)	2/21 (827)	3/16 (630)
Tube Diameter (mm)/Material	3/8 (9.5)/Copper	3/8 (9.5)/Copper	3/8 (9.5)/Copper
Number of Compressors	2	2	3
Phase	3	3	3
Volts	380-415	380-415	380-415
Compressor's RLA	6.7	9.5	9.5
Compressor's LRA	47.5	73.0	73.0
Indoor Blower's FLA	3.4	4.2	7.3
Outdoor Blower's FLA	1.7	1.7	1.7
Minimum Circuit Ampacity*	23.6	31.3	49.5
Maximum Fuse Size	30	50	60
Ship Weight lbs. (kg)	1,070 (485.8)	1,290 (585.7)	1,595 (724.1)

¹ Sensible capacity is gross with no deduction for indoor motor heat.

² BTU/Watt @ 80/67 °F (26.7/19.4 °C) inside; 95 °F (35 °C) outside air

* Wire size should be in accordance with Local Electrical Codes. Extensive wire runs will require larger wire sizes.

PRODUCT SPECIFICATIONS

DIMENSIONS (ALL DIMENSIONS IN INCHES AND MM: NO SCALE)

Figure 1: Vertical Discharge and Footprint

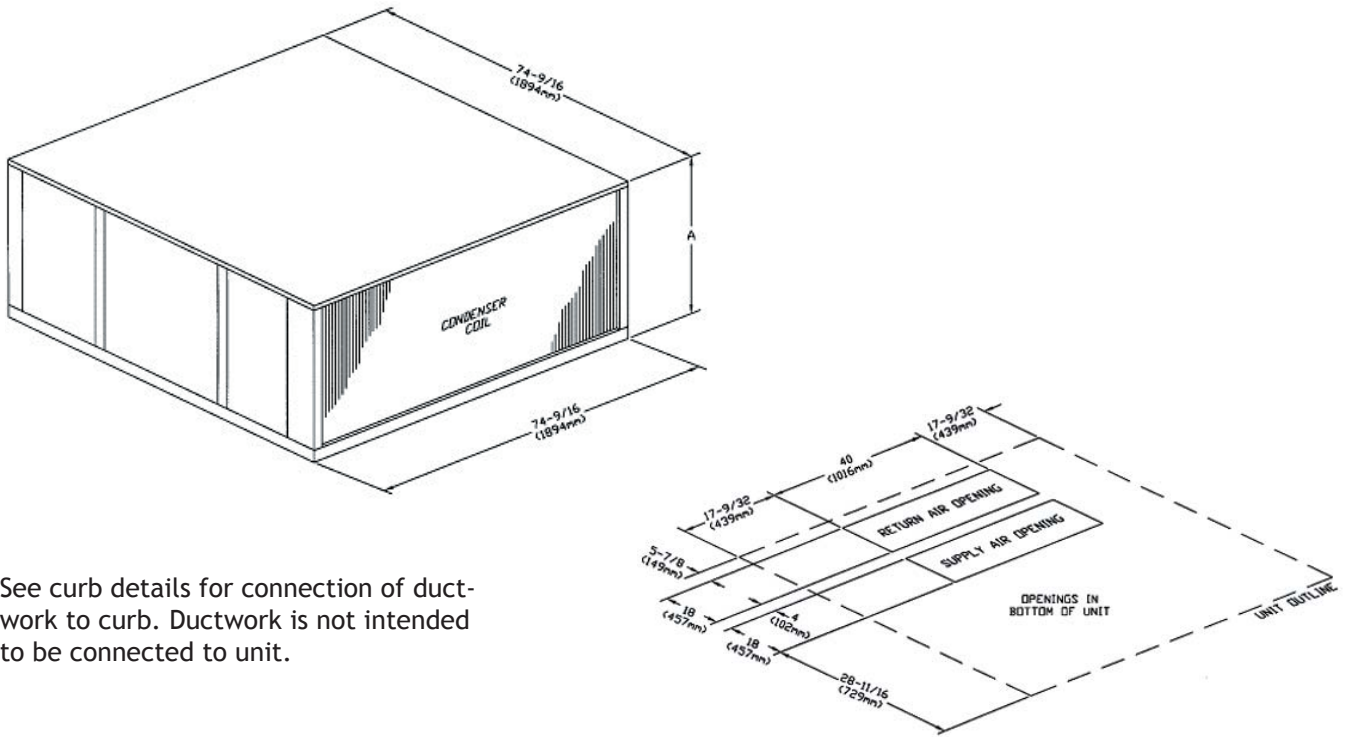

See curb details for connection of ductwork to curb. Ductwork is not intended to be connected to unit.

Figure 2: Horizontal Discharge

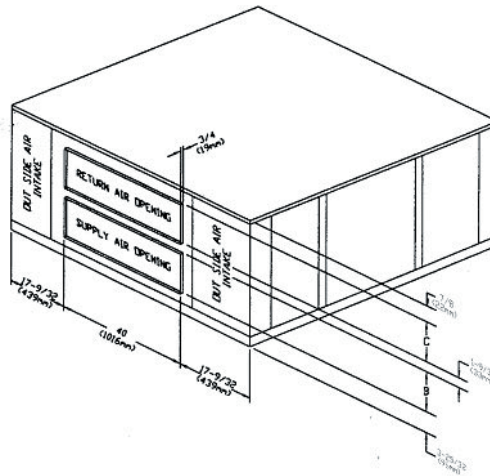

Model	A - Height	B - Supply Air	C - Return Air
PGB090210-5	36" (914 mm)	12½" (318 mm)	17 ⁹ / ₁₆ " (446 mm)
PGB120245-5 PGB180245-5	52" (1,321 mm)	20¼" (514 mm)	25 ¹³ / ₁₆ " (656 mm)

ELECTRICAL DIMENSIONS

Figure 3: Electrical Heat Units (cm)

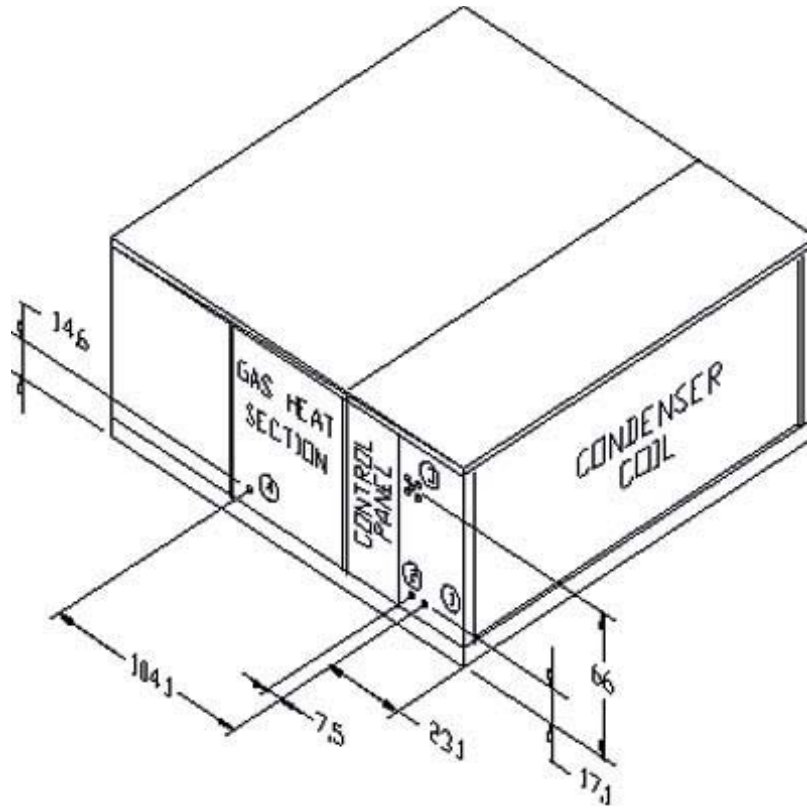

- 1) Main power entrance location
- 2) Control wiring entrance location
- 3) Option field installed internal disconnect switch
- 4) Gas piping entrance location

GAS PIPING CONNECTION SIZE

Furnace Size	Female NPT
PGB090210-5	1.9"
PGB120245-5	
PGB180245-5	

PRODUCT SPECIFICATIONS

FAN PERFORMANCE DATA

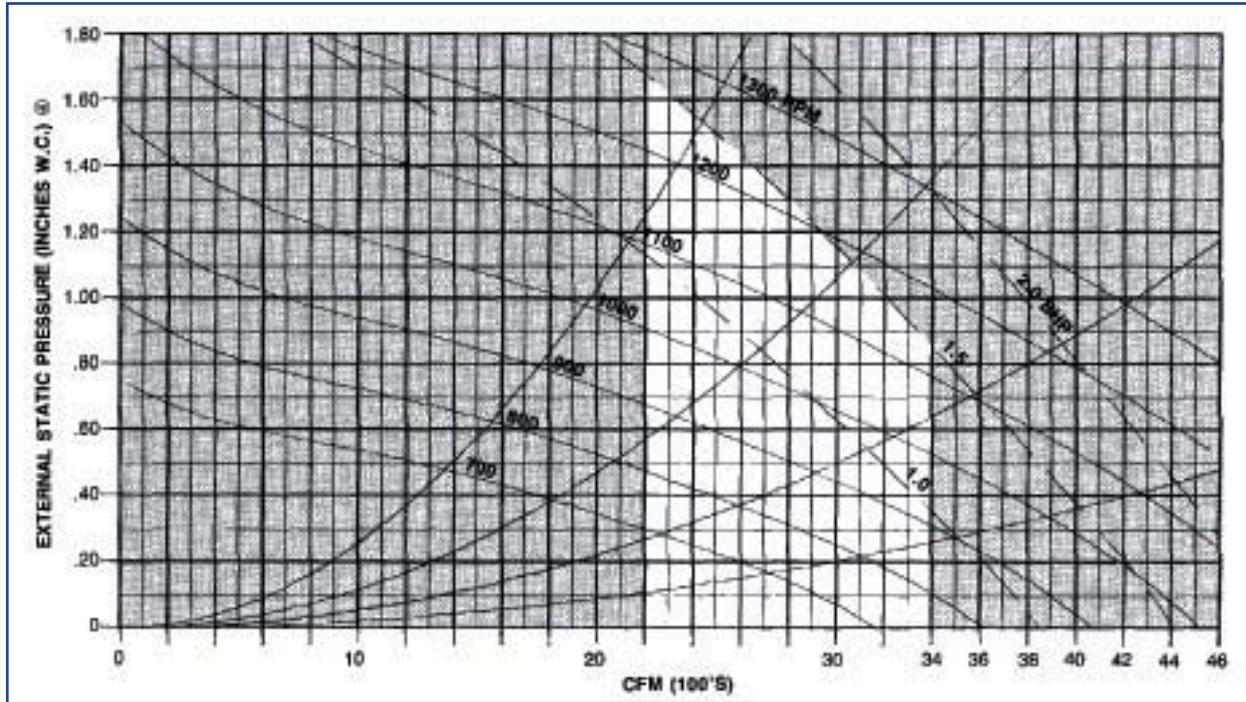

Figure 4: Fan Curve - PGB090210-5

SUPPLY FAN PERFORMANCE - PGB090210-5

CFM	External Static Pressure (Inches W.C.) See Last Note															
	0.2		0.4		0.6		0.8		1.0		1.2		1.4		1.6	
	RPM	BHP	RPM	BHP	RPM	BHP	RPM	BHP	RPM	BHP	RPM	BHP	RPM	BHP	RPM	BHP
2600	<i>669</i>	<i>0.44</i>	816	0.59	916	0.75	1004	0.92	1084	1.09	1157	1.28	<i>1226</i>	<i>1.47</i>	<i>1291</i>	<i>1.67</i>
2800	<i>734</i>	<i>0.53</i>	847	0.69	944	0.85	1030	1.03	1109	1.21	1181	1.40	<i>1249</i>	<i>1.60</i>	1312	1.91
3000	770	0.62	877	0.79	973	0.97	1053	1.15	1135	1.34	1206	1.54	1273	1.75	1336	1.96
3200	807	0.73	909	0.91	1002	1.10	1086	1.29	1162	1.49	1232	1.70	1298	1.91	1360	2.12
3400	845	0.85	942	1.04	1032	1.24	1114	1.44	1159	1.65	1259	1.87	1324	2.09	1384	2.31

- Selections in *Bold Italics* require a field drive change. See Table 2 for drive ranges.
- Table includes all internal pressure drops including cabinet losses. See Table 7 for additional pressure drops that must be considered as part of external static pressure drop.
- DO NOT SELECT IN SHADED AREAS (FOR INTERPOLATION ONLY)

SUPPLY FAN DRIVE DATA - PGB090210-5

Motor Sheave - Adjustable Factory Setting							
Fan Sheave - Fixed 2 Turns Opens							
Motor Sheave Turns Open	0	1	2	3	4	5	
Fan RPM	2.0 HP Motor	1209	1146	1082	1018	955	891

Note: Allow ±5% variation in blower RPM due to pulley manufacturing tolerances

Conversion Factor:

1 CFM = 0.472 L/S

1" W.C. = 2.5m bar

1 HP = 0.747 kW

FAN PERFORMANCE DATA (CONT.)

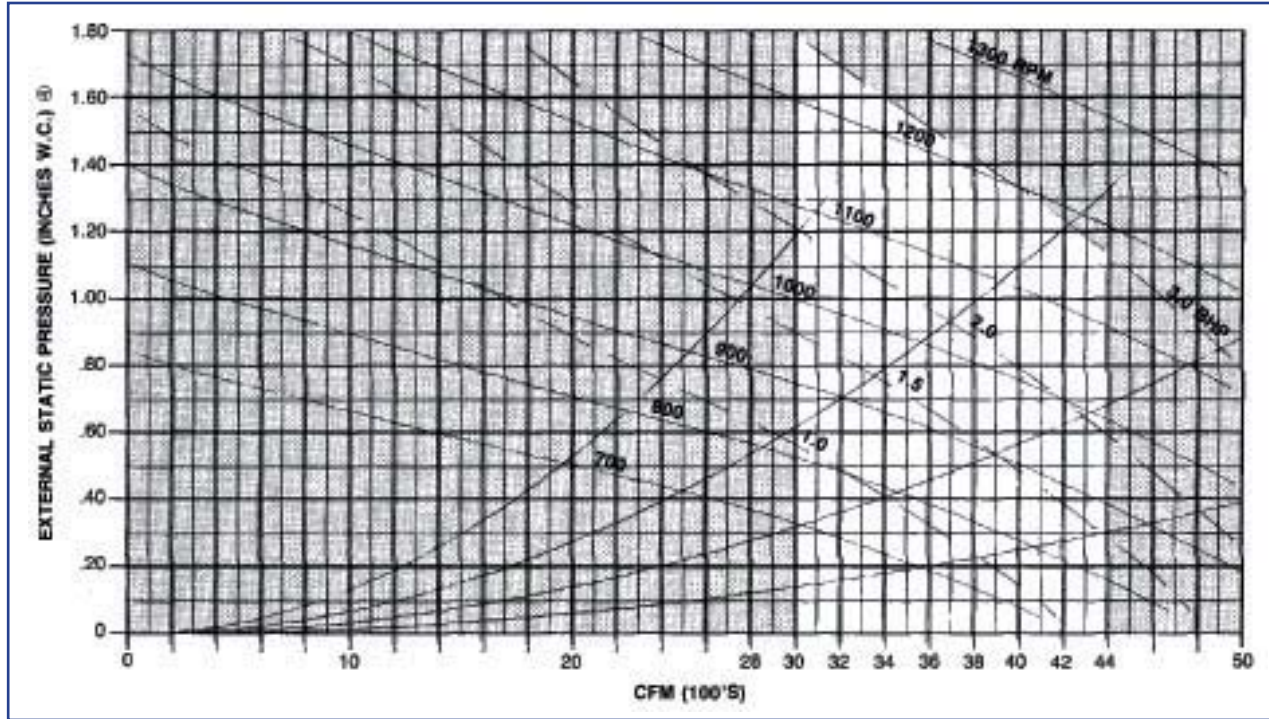

Figure 5: Fan Curve - PGB120245-5

SUPPLY FAN PERFORMANCE - PGB120245-5

External Static Pressure (Inches W.C.) SEE NOTE (3)																
CFM	0.2		0.4		0.6		0.8		1.0		1.2		1.4		1.6	
	RPM	BHP	RPM	BHP	RPM	BHP	RPM	BHP	RPM	BHP	RPM	BHP	RPM	BHP	RPM	BHP
3400	<i>679</i>	<i>0.73</i>	<i>781</i>	<i>0.98</i>	873	1.26	957	1.58	1034	1.91	1105	2.26	1171	2.26	1233	2.99
3600	<i>706</i>	<i>0.83</i>	805	1.10	894	1.39	975	1.71	1051	2.05	1121	2.41	1188	2.78	<i>1249</i>	<i>3.17</i>
3800	<i>733</i>	<i>0.95</i>	829	1.23	916	1.53	995	1.85	1069	2.20	1139	2.57	1204	2.95	1266	3.36
4000	<i>761</i>	<i>1.07</i>	855	1.37	938	1.68	1016	2.01	1088	2.36	1156	2.74	1221	3.14	1282	3.55
4200	790	1.21	880	1.52	961	1.84	1037	2.18	1108	2.54	1175	2.93	1239	3.33	1299	3.75
4400	818	1.36	906	1.68	985	2.01	1059	2.36	1128	2.73	1194	3.13	1257	3.54	1316	3.97

- Selections in *Bold Italics* require a field drive change. See Table 2 for drive ranges.
- Table includes all internal pressure drops including cabinet losses. See Table 7 for additional pressure drops that must be considered as part of external static pressure drop.
- DO NOT SELECT IN SHADED AREAS (FOR INTERPOLATION ONLY)

SUPPLY FAN DRIVE DATA - PGB120245-5

Motor Sheave - Adjustable Factory Setting							
Fan Sheave - Fixed 2 Turns Opens							
Motor Sheave Turns Open		0	1	2	3	4	5
FAN RPM	3.0 HP Motor	1242	1186	1129	1073	1016	960

Note: Allow ±5% variation in blower RPM due to pulley manufacturing tolerances

Conversion Factor:

1 CFM = 0.472 L/S

1" W.C. = 2.5m bar

1 HP = 0.747 kW

PRODUCT SPECIFICATIONS

FAN PERFORMANCE DATA (CONT.)

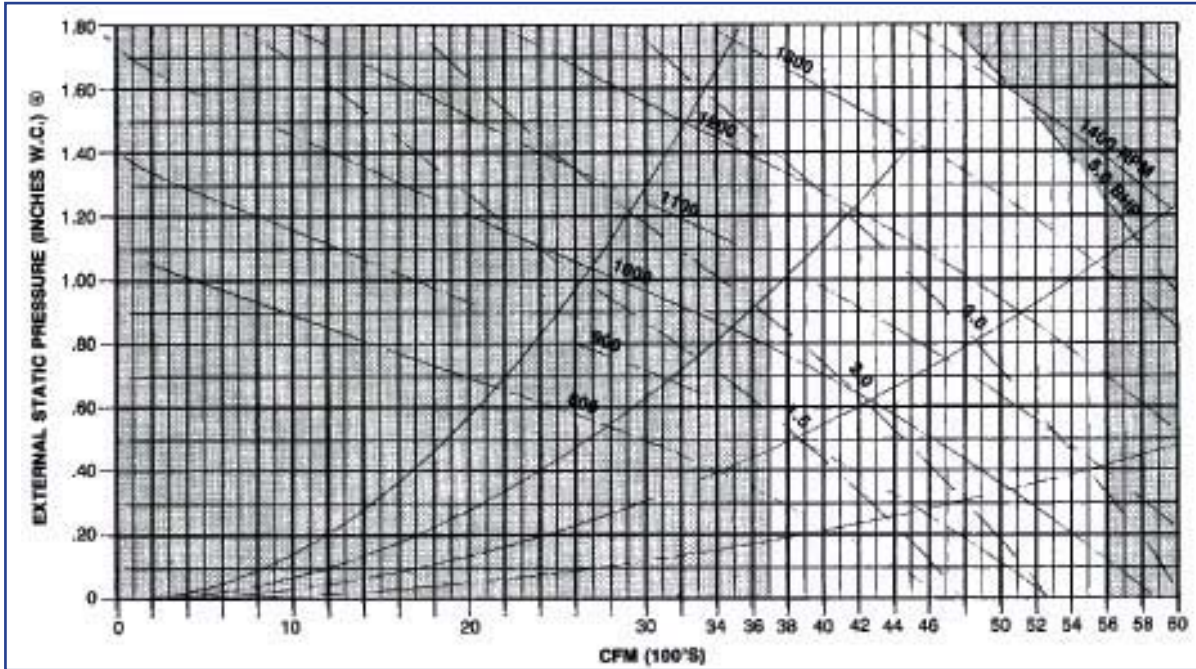

Figure 6: Fan Curve - PGB180245-5

SUPPLY FAN PERFORMANCE - PGB180245-5

CFM	External Static Pressure (Inches W.C.) SEE NOTE (3)															
	0.2		0.4		0.6		0.8		1.0		1.2		1.4		1.6	
	RPM	BHP	RPM	BHP	RPM	BHP	RPM	BHP	RPM	BHP	RPM	BHP	RPM	BHP	RPM	BHP
4000	<i>784</i>	<i>1.14</i>	<i>876</i>	<i>1.44</i>	959	1.76	1036	2.10	1108	2.47	1176	2.86	1239	3.26	1300	3.67
4200	<i>814</i>	<i>1.29</i>	<i>903</i>	<i>1.60</i>	983	1.93	1058	2.28	1129	2.66	1195	3.05	1258	3.46	1318	3.89
4400	<i>844</i>	<i>1.45</i>	930	1.78	1008	2.12	1081	2.48	1150	2.86	1215	3.26	1277	3.68	1337	4.12
4600	<i>874</i>	<i>1.63</i>	957	1.97	1034	2.32	1105	2.69	1172	3.08	1236	3.49	1297	3.92	1356	4.37
4800	<i>904</i>	<i>1.82</i>	986	2.17	1060	2.54	1129	2.92	1195	3.32	1258	3.74	1318	4.17	1375	4.63
5000	932	2.02	1014	2.39	1086	2.77	1159	3.16	1218	3.57	1280	4.00	1338	4.44	1395	4.91
5200	966	2.24	1043	2.62	1113	3.01	1179	3.42	1242	3.84	1302	4.27	1360	4.73	<i>1416</i>	<i>5.20</i>
5400	997	2.48	1071	2.87	1141	3.28	1205	3.70	1267	4.12	1326	4.57	1382	5.03	1437	5.51
5600	1029	2.74	1101	3.14	1168	3.56	1231	3.99	1291	4.43	1394	4.88	1405	5.36	1458	5.85

- Selections in *Bold Italics* require a field drive change. See Table 2 for drive ranges.
- Table includes all internal pressure drops including cabinet losses. See Table 7 for additional pressure drops that must be considered as part of external static pressure drop.
- DO NOT SELECT IN SHADED AREAS (FOR INTERPOLATION ONLY)

SUPPLY FAN DRIVE DATA - PGB180245-5

Motor Sheave - Adjustable Factory Setting							
Fan Sheave - Fixed 2 Turns Opens							
Motor Sheave Turns Open	0	1	2	3	4	5	
Fan RPM	5.0 HP Motor	1400	1446	1273	1209	1146	1082

Note: Allow ±5% variation in blower RPM due to pulley manufacturing tolerances

Conversion Factor:

1 CFM = 0.472 L/S

1" W.C. = 2.5m bar

1 HP = 0.747 kW

FAN PERFORMANCE DATA (CONT.)

COMPONENT PRESSURE DROPS (PGBs) W.C. (mBAR)

Model	Cfm (L/s)	Wet Coil	Gas Heat Section	Med. Eff. Filters	Econo. Return Air Damper
090210-5	2600 (1230)	0.06 (0.15)	0.10 (0.25)	0.03 (0.08)	0.14 (0.35)
	3000 (1840)	0.06 (0.15)	0.14 (0.35)	0.04 (0.10)	0.14 (0.35)
	3400 (1605)	0.07 (0.18)	0.17 (0.43)	0.05 (0.13)	0.18 (0.45)
120245-5	3600 (1700)	0.05 (0.13)	0.13 (0.33)	0.03 (0.08)	0.14 (0.35)
	4000 (1890)	0.05 (0.13)	0.16 (0.40)	0.04 (0.10)	0.14 (0.35)
	4400 (2080)	0.05 (0.13)	0.19 (0.48)	0.04 (0.10)	0.14 (0.35)
180245-5	5000 (2360)	0.13 (0.33)	0.27 (0.68)	0.06 (0.15)	0.18 (0.45)
	5400 (2550)	0.13 (0.33)	0.31 (0.78)	0.06 (0.15)	0.21 (0.53)
	5600 (2645)	0.16 (0.40)	0.34 (0.85)	0.08 (0.20)	0.23 (0.58)

FACTORY-SUPPLIED ACCESSORIES

Thermostat (CHT90-120)

A 2-stage cool/2-stage heat thermostat with subbase, manual changeover, Fan ON or AUTO. Note: A variety of thermostat configurations can be used on this equipment, based on the application needs. For example, our CHTS36-60 can be used if 2-stage cooling/single-stage heat is desired. Our CHT18-60 can be used if single-stage cooling and heating is desired. A single-stage cooling/2-stage heating thermostat can be used.

Rooftop Lift Kit (RLK90-120)

This kit consists of four ½" (12.7 mm) shackles that are used to lift the equipment into position on a roof, etc. The shackles are to be attached to the mounting holes in the base rails. Wire or strap material along with field-supplied spreader bars are employed to complete the lifting assembly (see rigging detail).

Low Ambient Control (LA-01)

This is a liquid temperature- (or pressure-) operated solid state control that varies the speed of one of the condenser fans. The low ambient control reduces fan motor RPM as liquid temperature (or pressure) decreases. Caution: If control is used below 50 °F (10 °C), accumulators should be added to the equipment to avoid slugging of the compressors.

Roof Curb (PGC-5)

This is a full perimeter curb for equipment in the down discharge application. Curb includes provisions for duct attachment prior to setting unit. Curb is shipped knocked down with all necessary hardware and gasket material.

Manual and Motorized Fresh Air Dampers (PGMD-5 & PGMDM-5)

The manual damper is fixed position type for 0% to 25% fresh air. Motorized damper is a field adjustable mechanical damper for 0% to 25% fresh air. Damper automatically closes when blower stops.

Economizers (PGED 090/102-5 & PGED 120/180-5)

Fully modulating, enthalpy-controlled economizers shipped with major components pre-assembled. Plug assembly on equipment and economizer provides easy wiring.

Horizontal Duct Kit (PGHDK 090/102-5 & PGHDK 120/180-5)

The unit is shipped in the downflow (vertical) duct configuration. The horizontal duct kit must be installed in the field for horizontal duct configuration.

Liquid Propane Kit (LPW-07)

The kit consists of an L.P. Gas (G31 Gas) spring and main gas orifices to convert appliance from natural gas (G20 Gas) to liquid propane fuel (G31 gas).

Panel Louver Kit (PLK090/102-5 & PLK120/180-5)

Louvered panels for condenser coil protection.

Phase Rotation Monitor (B13705-03)

This kit will detect phase reversal and phase loss across any three lines and will immediately turn the load off. Once the load is off, it will stay off (lockout) until the control voltage is turned off and turned on again.

PRODUCT SPECIFICATIONS

COOLING CAPACITY DATA

Note: Total and Sensible capacities are gross and do not take into consideration motor heat. Refer to page 10 for information about motor heat.

TABLE 1A: PGB090210-5 (SI UNITS)

Indoor Air		Condenser Air Temperature														
L/S	WB	23.9°C			29.4°C			35.0°C			40.6°C			46.1°C		
		Total Cap.	Sens Cap.	kW	Total Cap.	Sens Cap.	kW	Total Cap.	Sens Cap.	kW	Total Cap.	Sens Cap.	kW	Total Cap.	Sens Cap.	kW
1203	22.2	32.77	15.48	8.36	30.67	14.52	9.29	28.56	13.56	10.23	26.46	12.60	11.17	24.35	11.64	12.10
	19.4	30.23	18.70	7.82	28.17	17.90	8.73	26.11	17.10	9.64	24.05	16.31	10.55	21.99	15.51	11.46
	16.7	27.52	23.00	7.46	26.07	21.73	8.30	24.62	20.45	9.14	23.17	19.18	9.98	21.72	17.91	10.82
	13.9	26.59	24.96	7.18	24.98	23.20	8.06	23.38	21.43	8.94	21.77	19.67	9.83	20.17	17.91	10.71
1416	22.2	34.17	17.16	8.63	31.91	16.15	9.58	29.65	15.14	10.53	27.39	14.14	11.48	25.13	13.13	12.43
	19.4	31.36	21.95	8.08	29.28	20.81	9.01	27.20	19.66	9.93	25.12	18.52	10.86	23.03	17.38	11.78
	16.7	28.62	26.83	7.53	26.96	25.02	8.49	25.30	23.20	9.44	23.65	21.39	10.40	21.99	19.58	11.35
	13.9	28.62	26.83	7.53	26.96	25.02	8.49	25.30	23.20	9.44	23.65	21.39	10.40	21.99	19.58	11.35
1628	22.2	35.01	18.42	8.82	32.73	17.46	9.77	30.46	16.50	10.73	28.18	15.54	11.69	25.90	14.59	12.64
	19.4	32.19	24.67	8.28	30.10	23.35	9.21	28.00	22.04	10.14	25.91	20.72	11.07	23.81	19.40	11.99
	16.7	30.24	28.49	7.89	28.44	26.54	8.86	26.64	24.60	9.84	24.84	22.65	10.81	23.03	20.71	11.78
	13.9	30.24	28.49	7.89	28.44	26.54	8.86	26.64	24.60	9.84	24.84	22.65	10.81	23.03	20.71	11.78

Sensible heat capacities shown are based on 26.7°C DB entering air at the evaporator coil. For sensible heat capacities at other than 26.7°C DB, deduct 44.32 W per 47 L/S of evaporator coil air for each degree below 26.7°C, or add 44.32 W per 47 L/S of evaporator coil air per degree above 26.7°C.

TABLE 1B: PGB090210-5 (ENGLISH UNITS)

Indoor Air		Condenser Air Temperature														
SCFM	WB	75°F			85°F			95°F			105°F			115°F		
		Total KBTU/h	Sens KBTU/h	kW	Total KBTU/h	Sens KBTU/h	kW	Total KBTU/h	Sens KBTU/h	kW	Total KBTU/h	Sens KBTU/h	kW	Total KBTU/h	Sens KBTU/h	kW
2550	72	111.8	52.8	8.36	104.6	49.6	9.29	97.5	46.3	10.23	90.3	43.0	11.17	83.1	39.7	12.10
	67	103.2	63.8	7.82	96.1	61.1	8.73	89.1	58.4	9.64	82.1	55.6	10.55	75.0	52.9	11.46
	62	93.9	78.5	7.46	89.0	74.1	8.30	84.0	69.8	9.14	79.1	65.5	9.98	74.1	61.1	10.82
	57	90.7	85.2	7.18	85.2	79.1	8.06	79.8	73.1	8.94	74.3	67.1	9.83	68.8	61.1	10.71
3000	72	116.6	58.5	8.63	108.9	55.1	9.58	101.2	51.7	10.53	93.5	48.2	11.48	85.7	44.8	12.43
	67	107.0	74.9	8.08	99.9	71.0	9.01	92.8	67.1	9.93	85.7	63.2	10.86	78.6	59.3	11.78
	62	97.6	91.6	7.53	92.0	85.4	8.49	86.3	79.2	9.44	80.7	73.0	10.40	75.0	66.8	11.35
	57	97.6	91.6	7.53	92.0	85.4	8.49	86.3	79.2	9.44	80.7	73.0	10.40	75.0	66.8	11.35
3450	72	119.5	62.9	8.82	111.7	59.6	9.77	103.9	56.3	10.73	96.2	53.0	11.69	88.4	49.8	12.64
	67	109.9	84.2	8.28	102.7	79.7	9.21	95.6	75.2	10.14	88.4	70.7	11.07	81.3	66.2	11.99
	62	103.2	97.2	7.89	97.0	90.6	8.86	90.9	83.9	9.84	84.7	77.3	10.81	78.6	70.7	11.78
	57	103.2	97.2	7.89	97.0	90.6	8.86	90.9	83.9	9.84	84.7	77.3	10.81	78.6	70.7	11.78

Sensible heat capacities shown are based on 80°F DB entering air at the evaporator coil. For sensible heat capacities at other than 80°F DB, deduct 84 BTU/h per 100 CFM of evaporator coil air for each degree below 80°F, or add 84 BTU/h per 100 CFM of evaporator coil air per degree above 80°F.

TABLE 2A: PGB120245-5 (SI UNITS)

Indoor Air		Condenser Air Temperature														
L/S	WB	23.9°C			29.4°C			35.0°C			40.6°C			46.1°C		
		Total Cap.	Sens Cap.	kW	Total Cap.	Sens Cap.	kW	Total Cap.	Sens Cap.	kW	Total Cap.	Sens Cap.	kW	Total Cap.	Sens Cap.	kW
1605	22.2	43.67	21.02	9.95	41.04	19.52	11.27	38.41	18.03	12.59	35.78	16.54	13.91	33.15	15.04	15.23
	19.4	40.29	25.44	9.31	37.70	24.09	10.59	35.11	22.74	11.86	32.52	21.38	13.14	29.93	20.03	14.41
	16.7	36.65	31.24	8.89	34.88	29.22	10.07	33.11	27.19	11.25	31.34	25.17	12.43	29.57	23.14	13.61
	13.9	35.42	33.85	8.54	33.43	31.17	9.78	31.44	28.49	11.01	29.45	25.82	12.24	27.45	23.14	13.47
1888	22.2	45.54	23.30	10.28	42.71	21.72	11.62	39.87	20.13	12.96	37.04	18.55	14.30	34.20	16.96	15.64
	19.4	41.79	29.83	9.62	39.18	27.99	10.92	36.57	26.14	12.22	33.97	24.29	13.52	31.36	22.45	14.82
	16.7	38.12	36.41	8.95	36.07	33.63	10.29	34.03	30.85	11.62	31.98	28.07	12.95	29.93	25.29	14.29
	13.9	38.12	36.41	8.95	36.07	33.63	10.29	34.03	30.85	11.62	31.98	28.07	12.95	29.93	25.29	14.29
2170	22.2	46.65	25.03	10.50	43.81	23.49	11.85	40.96	21.94	13.20	38.11	20.39	14.55	35.26	18.84	15.90
	19.4	42.90	33.53	9.86	40.28	31.41	11.17	37.66	29.29	12.48	35.04	27.18	13.78	32.41	25.06	15.09
	16.7	40.29	38.65	9.39	38.05	35.67	10.75	35.82	32.70	12.11	33.59	29.72	13.46	31.36	26.75	14.82
	13.9	40.29	38.65	9.39	38.05	35.67	10.75	35.82	32.70	12.11	33.59	29.72	13.46	31.36	26.75	14.82

Sensible heat capacities shown are based on 26.7°C DB entering air at the evaporator coil. For sensible heat capacities at other than 26.7°C DB, deduct 44.32 W per 47 L/S of evaporator coil air for each degree below 26.7°C, or add 44.32 W per 47 L/S of evaporator coil air per degree above 26.7°C.

COOLING CAPACITY DATA (CONT.)

Table 2B: PGB120245-5 (English Units)

Indoor Air		Condenser Air Temperature														
		75°F			85°F			95°F			105°F			115°F		
SCFM	WB	Total KBTU/h	Sens KBTU/h	kW	Total KBTU/h	Sens KBTU/h	kW	Total KBTU/h	Sens KBTU/h	kW	Total KBTU/h	Sens KBTU/h	kW	Total KBTU/h	Sens KBTU/h	kW
3400	72	149.0	71.7	9.95	140.0	66.6	11.27	131.1	61.5	12.59	122.1	56.4	13.91	113.1	51.3	15.23
	67	137.5	86.8	9.31	128.6	82.2	10.59	119.8	77.6	11.86	111.0	73.0	13.14	102.1	68.4	14.41
	62	125.1	106.6	8.89	119.0	99.7	10.07	113.0	92.8	11.25	106.9	85.9	12.43	100.9	79.0	13.61
	57	120.9	115.5	8.54	114.1	106.4	9.78	107.3	97.2	11.01	100.5	88.1	12.24	93.7	79.0	13.47
4000	72	155.4	79.5	10.28	145.7	74.1	11.62	136.1	68.7	12.96	126.4	63.3	14.30	116.7	57.9	15.64
	67	142.6	101.8	9.62	133.7	95.5	10.92	124.8	89.2	12.22	115.9	82.9	13.52	107.0	76.6	14.82
	62	130.1	124.2	8.95	123.1	114.7	10.29	116.1	105.3	11.62	109.1	95.8	12.95	102.1	86.3	14.29
	57	130.1	124.2	8.95	123.1	114.7	10.29	116.1	105.3	11.62	109.1	95.8	12.95	102.1	86.3	14.29
4600	72	159.2	85.4	10.50	149.5	80.1	11.85	139.8	74.9	13.20	130.0	69.6	14.55	120.3	64.3	15.90
	67	146.4	114.4	9.86	137.5	107.2	11.17	128.5	100.0	12.48	119.6	92.7	13.78	110.6	85.5	15.09
	62	137.5	131.9	9.39	129.9	121.7	10.75	122.2	111.6	12.11	114.6	101.4	13.46	107.0	91.3	14.82
	57	137.5	131.9	9.39	129.9	121.7	10.75	122.2	111.6	12.11	114.6	101.4	13.46	107.0	91.3	14.82

Sensible heat capacities shown are based on 80°F DB entering air at the evaporator coil. For sensible heat capacities at other than 80°F DB, deduct 84 BTU/h per 100 CFM of evaporator coil air for each degree below 80°F, or add 84 BTU/h per 100 CFM of evaporator coil air per degree above 80°F.

Table 3A: PGB180245-5 (SI Units)

INDOOR AIR		CONDENSER AIR TEMPERATURE														
		23.9°C			29.4°C			35.0°C			40.6°C			46.1°C		
L/S	WB	Total Cap.	Sens Cap.	kW	Total Cap.	Sens Cap.	kW	Total Cap.	Sens Cap.	kW	Total Cap.	Sens Cap.	kW	Total Cap.	Sens Cap.	kW
2246	22.2	64.17	29.53	16.42	60.17	28.00	18.63	56.17	26.48	20.83	52.17	24.95	23.04	48.17	23.43	25.25
	19.4	59.19	35.59	15.36	55.27	34.49	17.50	51.35	33.39	19.63	47.42	32.29	21.76	43.50	31.20	23.89
	16.7	53.86	43.83	14.67	51.14	41.88	16.64	48.42	39.93	18.61	45.69	37.99	20.59	42.97	36.04	22.56
	13.9	52.05	47.66	14.10	49.01	44.75	16.15	45.97	41.85	18.21	42.93	38.94	20.27	39.90	36.04	22.33
2643	22.2	66.90	32.71	16.97	62.61	31.14	19.21	58.31	29.56	21.45	54.01	27.99	23.68	49.71	26.42	25.92
	19.4	61.40	41.82	15.87	57.44	40.10	18.05	53.48	38.39	20.22	49.53	36.68	22.40	45.57	34.96	24.57
	16.7	56.02	51.22	14.77	52.89	48.26	17.00	49.76	45.30	19.23	46.63	42.34	21.46	43.50	39.38	23.68
	13.9	56.02	51.22	14.77	52.89	48.26	17.00	49.76	45.30	19.23	46.63	42.34	21.46	43.50	39.38	23.68
3039	22.2	68.54	35.09	17.33	64.22	33.66	19.59	59.89	32.22	21.85	55.57	30.78	24.11	51.24	29.34	26.37
	19.4	63.03	47.01	16.27	59.05	45.02	18.46	55.07	43.02	20.64	51.09	41.02	22.83	47.11	39.03	25.01
	16.7	59.20	54.38	15.49	55.79	51.20	17.76	52.38	48.02	20.03	48.98	44.84	22.30	45.57	41.66	24.57
	13.9	59.20	54.38	15.49	55.79	51.20	17.76	52.38	48.02	20.03	48.98	44.84	22.30	45.57	41.66	24.57

Sensible heat capacities shown are based on 26.7°C DB entering air at the evaporator coil. For sensible heat capacities at other than 26.7°C DB, deduct 44.32 W per 47 L/S of evaporator coil air for each degree below 26.7°C, or add 44.32 W per 47 L/S of evaporator coil air per degree above 26.7°C.

Table 3B: PGB180245-5 (English Units)

INDOOR AIR		CONDENSER AIR TEMPERATURE														
		75°F			85°F			95°F			105°F			115°F		
SCFM	WB	Total KBTU/h	Sens KBTU/h	kW	Total KBTU/h	Sens KBTU/h	kW	Total KBTU/h	Sens KBTU/h	kW	Total KBTU/h	Sens KBTU/h	kW	Total KBTU/h	Sens KBTU/h	kW
4760	72	219.0	100.8	16.42	205.3	95.6	18.63	191.7	90.4	20.83	178.0	85.1	23.04	164.4	79.9	25.25
	67	202.0	121.4	15.36	188.6	117.7	17.50	175.2	113.9	19.63	161.8	110.2	21.76	148.4	106.5	23.89
	62	183.8	149.6	14.67	174.5	142.9	16.64	165.2	136.3	18.61	155.9	129.6	20.59	146.6	123.0	22.56
	57	177.6	162.6	14.10	167.2	152.7	16.15	156.9	142.8	18.21	146.5	132.9	20.27	136.1	123.0	22.33
5600	72	228.3	111.6	16.97	213.6	106.3	19.21	199.0	100.9	21.45	184.3	95.5	23.68	169.6	90.1	25.92
	67	209.5	142.7	15.87	196.0	136.9	18.05	182.5	131.0	20.22	169.0	125.2	22.40	155.5	119.3	24.46
	62	191.1	174.8	14.77	180.5	164.7	17.00	169.8	154.6	19.23	159.1	144.5	21.46	148.4	134.4	23.68
	57	191.1	174.8	14.77	180.5	164.7	17.00	169.8	154.6	19.23	159.1	144.5	21.46	148.4	134.4	23.68
6440	72	233.9	119.7	17.33	219.1	114.8	19.59	204.4	109.9	21.85	189.6	105.0	24.11	174.9	100.1	26.37
	67	215.1	160.4	16.27	201.5	153.6	18.46	187.9	146.8	20.64	174.3	140.0	22.83	160.7	133.2	25.01
	62	202.0	185.6	15.49	190.4	174.7	17.76	178.8	163.9	20.03	167.1	153.0	22.30	155.5	142.1	24.57
	57	202.0	185.6	15.49	190.4	174.7	17.76	178.8	163.9	20.03	167.1	153.0	22.30	155.5	142.1	24.57

Sensible heat capacities shown are based on 80°F DB entering air at the evaporator coil. For sensible heat capacities at other than 80°F DB, deduct 84 BTU/h per 100 CFM of evaporator coil air for each degree below 80°F, or add 84 BTU/h per 100 CFM of evaporator coil air per degree above 80°F.

PRODUCT SPECIFICATIONS

COOLING CAPACITY DATA (CONT.)

EVAPORATOR MOTOR HEAT

Horsepower/(KW)	BTU/h/(KW)
2 (1.49)	4400 (1.29)
3 (2.24)	6200 (1.82)
5 (3.73)	10,500 (3.08)

GAS FURNACE AIR TEMPERATURE RISE ° F (° C)

		PGB090210-5	PGB120245-5 PGB180245-5
Number of Tubes		6	7
Ventor Motor HP (kW)		1/16 (0.05)	1/12 (0.06)
Heat Input BTU/h (kW)		204,000 (59.8)	238,000 (69.7)
Heat Output BTU/h (kW)		162,200 (47.5)	185,600 (54.4)
Airflow CFM (L/S*)	3000 (1400)	51.1 (28.4)	-
	3200 (1500)	47.7 (26.5)	55.6 (30.9)
	3400 (1600)	44.6 (24.8)	52.2 (29.0)
	3600 (1700)	42.1 (23.4)	49.1 (27.3)
	3800 (1800)	39.8 (22.1)	46.4 (25.8)
	4050 (1900)	37.6 (20.9)	43.9 (24.4)
	4250 (2000)	35.8 (19.9)	41.8 (23.2)
	4450 (2100)	34.0 (18.9)	39.8 (22.1)
	4650 (2200)	32.6 (18.1)	38.0 (21.1)
	4900 (2300)	31.1 (17.3)	36.4 (20.2)
	5100 (2400)	29.8 (16.6)	34.7 (19.3)
	5300 (2500)	28.6 (15.9)	33.3 (18.5)
	5500 (2600)	27.5 (15.3)	32.0 (17.8)
	5750 (2700)	26.5 (14.7)	31.0 (17.2)
	5950 (2800)	25.6 (14.2)	29.9 (16.6)

Notes:

- Capacities are approved for altitudes to 2,000' (610 m). At higher elevations, heating capacity must be reduced 4% (x0.96) for each 1,000' (305 m) above sea level.
- Air temperature rise is for total heating capacity. Temperature rises at other conditions may be calculated by using the formula:

$$\text{Temperature Rise (}^\circ\text{F)} = \frac{\text{Output Capacity (BTU/h)}}{1.08 \times \text{Air Flow (CFM)}} \quad (^\circ\text{C)} = 828.3 \times \frac{\text{Output Capacity (Kilowatts)}}{\text{Air Flow (Liter/Second)}}$$

- For altitudes over 2,000' (610 m), air temperature rise must be calculated using the formula:

$$\text{Temperature Rise (}^\circ\text{F)} = \frac{\text{Output Capacity (Kilowatts)}}{14.4 \times \text{Air Flow (CFM)} \times \text{Specific Weight of Air}} \quad (^\circ\text{C)} = \frac{1791.4 \times \text{Output Capacity (Kilowatts)}}{\text{Air Flow (Liter/Second)} \times \text{Density of Air (Kg./m}^3\text{)}}$$

- Output capacity based on nominal 1,000 BTU/ft³ (10.34 kW/m³) for natural gas or 2,500 BTU/ft³ (25.87 kW/m³) for propane.

Quality Makes the Difference!

All of our systems are designed and manufactured with the same high-quality standards, regardless of size or efficiency. We have designed these units to significantly reduce the most frequent causes of product failure and use quality materials and components. They are simple to service and forgiving to operate. Finally, every unit is run-tested before it leaves the factory. That's why we know... there's no better quality.

Visit our website at
www.goodmanmfg.com for information on:
Goodman Products • Customer Services • Parts

Goodman Manufacturing Company, L.P.
2550 North Loop West, Suite 400
Houston, Texas 77092 USA

Goodman Manufacturing Company, L.P., reserves the right to discontinue, or change at any time, specifications or designs without notice or without incurring obligations.
Copyright © 2007 Goodman Manufacturing Company, L.P. • Houston, Texas • Printed in the USA.