



Air Conditioning & Heating

MBVC

VARIABLE-SPEED, COMFORTNET™- COMPATIBLE MODULAR BLOWERS

**COOLING CAPACITY:
18,000 - 60,000 BTU/H**

Standard Features

- Compatible with the ComfortNet™ Communication System family of products
- Variable-speed ECM blower motor
- Auto configuration of the airflow and tonnage in communicating mode
- CFM indicator
- Maximum four low-voltage wires required for operation in communicating mode
- Built-in dehumidify feature
- Diagnostic indicator lights
- Storage of six prior fault codes
- Programmable heat strip settings
- Color-coded terminal strip for non-communicating set-up
- Cooling and heat pump applications
- AHRI Certified
- ETL Listed

Cabinet Features

- Painted, galvanized steel cabinet
- Blower section usable as an electric furnace
- Foil-faced insulation is glued in place and covers the entire blower case, reducing sound and cabinet condensation
- Bottom flanges formed inward for additional strength, and to provide mounting surface for cased-coil section



* Complete warranty details available from your local dealer or at www.goodmanmfg.com. To receive the 10-Year Parts Limited Warranty, online registration must be completed within 60 days of installation. Online registration is not required in California or Québec.



NOMENCLATURE

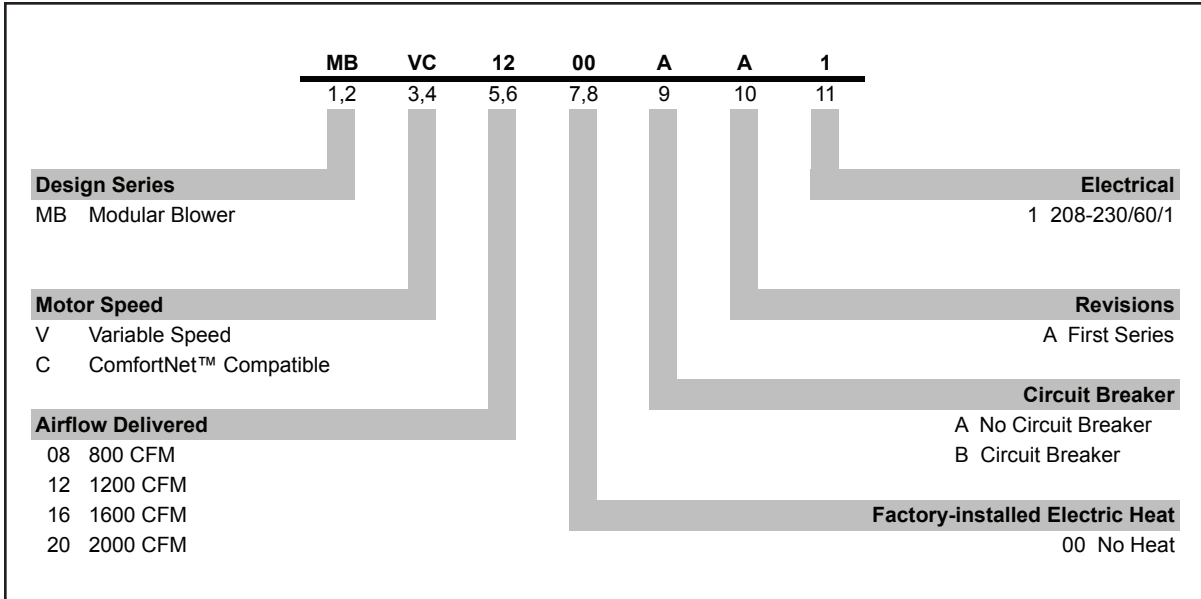

SPECIFICATIONS

MODEL	CFM @ 0.3" ESP (HIGH TO LOW)	VOLTAGE- PHASE	MCA*	MOP*	BLOWER DIMENSIONS		MOTOR HP	SHIP WEIGHT (LBS)
					DIAMETER	WIDTH		
MBVC1200AA-1	1,200 to 600	208/230-1	4.3	15	10"	8"	½	73
MBVC1600AA-1	1,600 to 1,000	208/230-1	6.3	15	10"	8"	¾	83
MBVC2000AA-1	2,000 to 1,200	208/230-1	5.8	15	11"	10"	¾	95

* Minimum Circuit Ampacity (MCA) and Maximum Overcurrent Protection (MOP) for blower without supplemental heat installed. Refer to unit name-plate for these specifications with approved accessory heaters installed.

HEAT KIT SELECTION

	MBVC1200 AA-1A*	MBVC1600 AA-1A*	MBVC2000 AA-1A*
HKR-03*	X	X	X
HKR-05*/-05C*	X	X	X
HKR-06*	X	X	X
HKR-08*/-08C*	X	X	X
HKR-10*/-10C*	X	X	X
HKR-15C*	X	X	X
HKR-20C*			X

X Allowable combinations

* Indicates revision level that may or may not be designated

C Indicates Circuit Breaker option

SINGLE POINT KIT **

MODEL	HKR-15C	HKR-20C	HKR-21C
SPW-01	X	X	X

** Must be installed along with any of the above compatible heat kits. This kit will fit any MBVC blower as long as a compatible heat kit is installed in the unit.

COOLING / HP AIRFLOW

S1	S2	SPEED TAP	MBVC1200 AIRFLOW (SCFM)	MBVC1600 AIRFLOW (SCFM)	MBVC2000 AIRFLOW (SCFM)
off	off	A	600	1000	1200
on	off	B	800	1200	1600
off	on	C	1000	1400	1800
on	on	D	1200	1600	2000

COOLING / HP / AUX TRIM			COOLING PROFILE		
S3	S4	Trim Value	S5	S6	
off	off	0	off	off	A
on	off	10%	on	off	B
off	on	-10%	off	on	C
on	on	0	on	on	D

HEATER KIT kW AIRFLOW

S9	S10	S11	HEATER KW	MBVC1200 AIRFLOW (SCFM)	MBVC1600 AIRFLOW (SCFM)	MBVC2000 AIRFLOW (SCFM)
off	off	off	21	NA	NA	NA
off	off	on	20	NA	NA	2000
off	on	off	15	1400	1500	1500
off	on	on	10	1000	1000	1200
on	off	off	8	740	1000	1000
on	off	on	6	635	800	800
on	on	off	5	600	800	800
on	on	on	3	600	800	800

MBVC BLOWER PERFORMANCE DATA — DIPSWITCH SUMMARY

DIPSWITCH #	FUNCTION	DEFAULT SETTING
S1 - S2*	Cooling / HP Airflow A/B/C/D	Airflow D
S3 - S4*	Cooling / HP / Aux Trim (-10%, 0, +10%)	No Trim
S5 - S6*	Cooling Profile A,B,C,D	Profile 1
S7*	Dehum (on/off)	Off
S8	Unused	On
S9 - S11	Heater Kit Kw	Off/Off/Off

* Valid only if the system is wired in legacy mode. If system is wired in the 4-wire communicating mode, these functions are selected via the user menu in the CTK01AA T-STAT.

DIMENSIONS

SIDE AND FRONT VIEWS

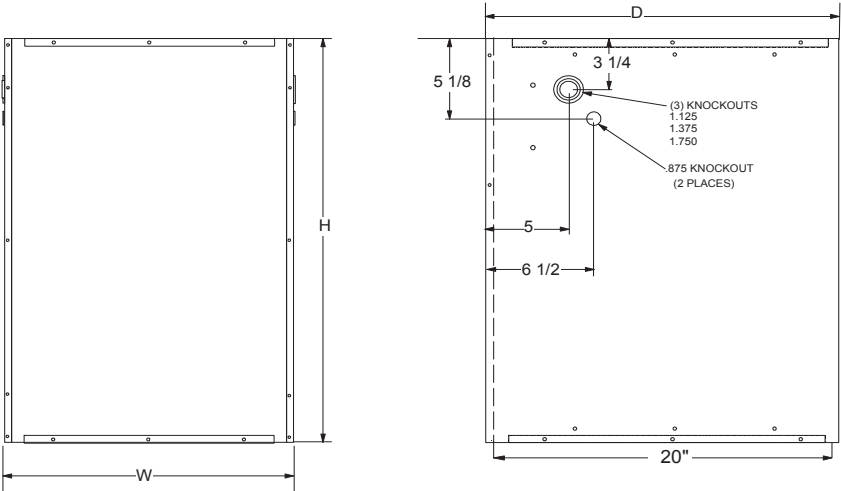

MODEL	DIMENSIONS		
	WIDTH	DEPTH	HEIGHT
MBVC1200AA-1	17½"	21"	26"
MBVC1600AA-1	21"	21"	30"
MBVC2000AA-1	24½"	21"	30"

TOP VIEW

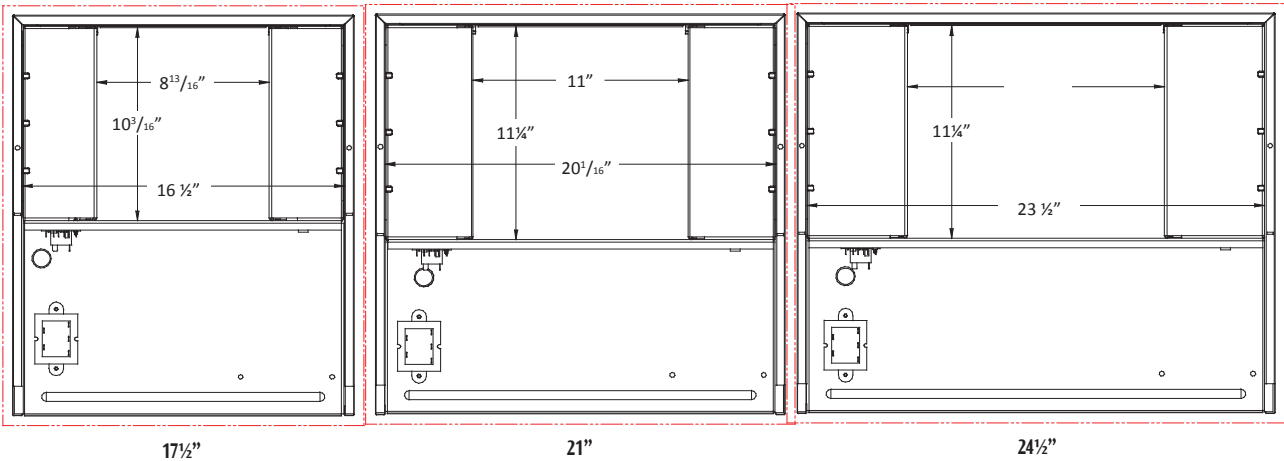

WIRING DIAGRAMS

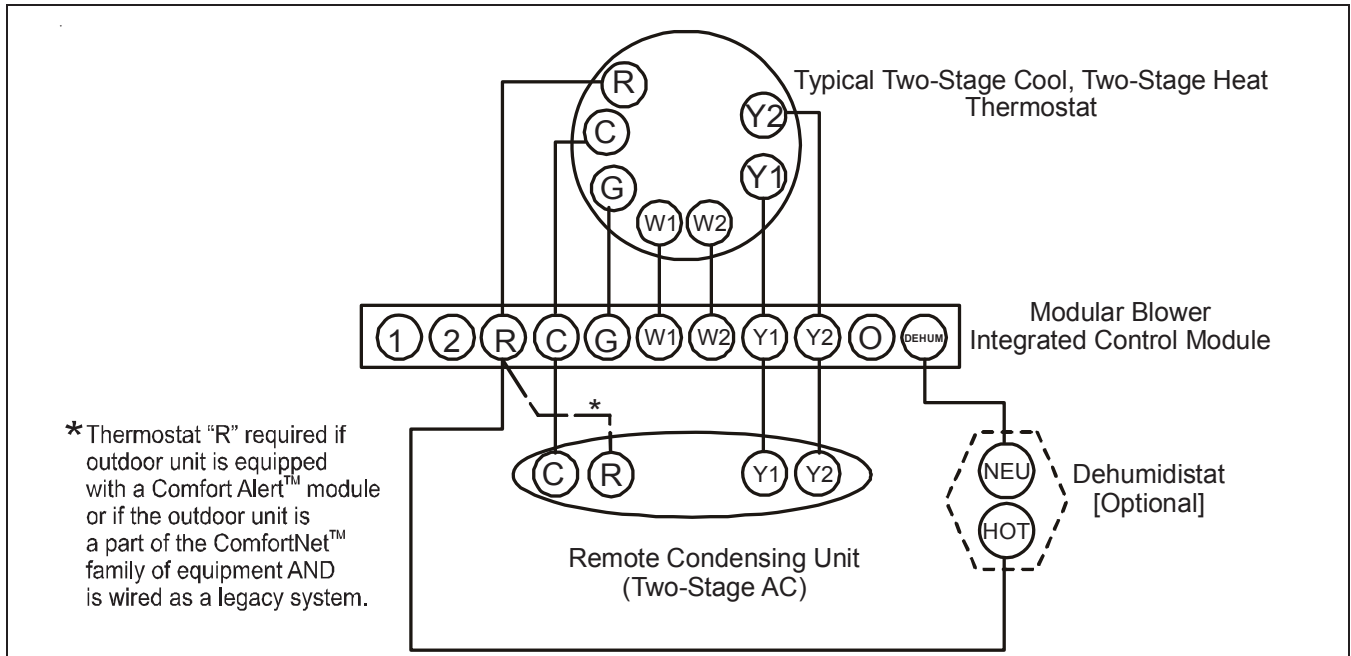

Typical Two-Stage Cooling with Two-Stage Heating

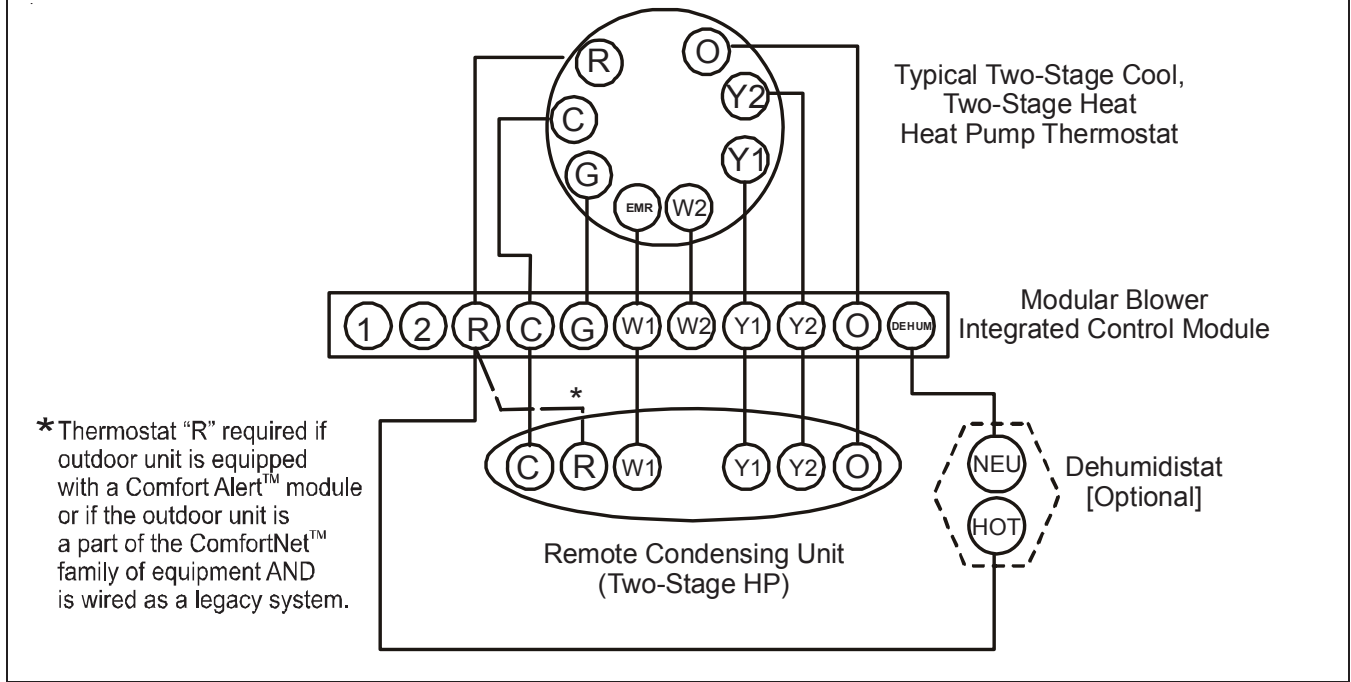

TYPIAL TWO-STAGE HEAT PUMP HEATING AND AUXILIARY/EMERGENCY HEATING

Wiring is subject to change. Always refer to the wiring diagram or the unit for the most up-to-date wiring.

	WARNING	<p>High Voltage: Disconnect all power before servicing or installing this unit. Multiple power sources may be present. Failure to do so may cause property damage, personal injury, or death.</p>	
--	----------------	--	--

WIRING DIAGRAMS (CONT.)

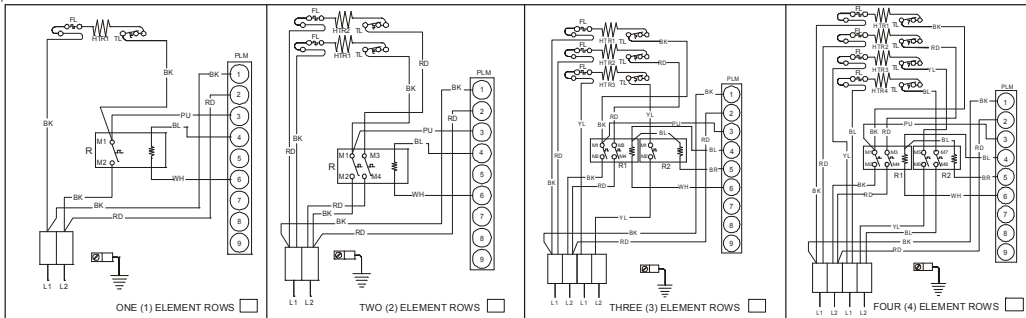

NOTE: WHEN INSTALLING HEATER KIT, ENSURE SPEED TAP DOES NOT EXCEED MINIMUM BLOWER SPEED (MBS) SPECIFIED FOR THE AIRHANDLER/HEATER KIT COMBINATION ON THIS UNIT'S S&R PLATE. AFTER INSTALLING OPTIONAL HEAT KIT, MARK AN "X" IN THE PROVIDED ABOVE. MARK ACCORDING TO NUMBER OF HEATER ELEMENT ROWS INSTALLED. NO MARK INDICATES NO HEAT KIT INSTALLED.

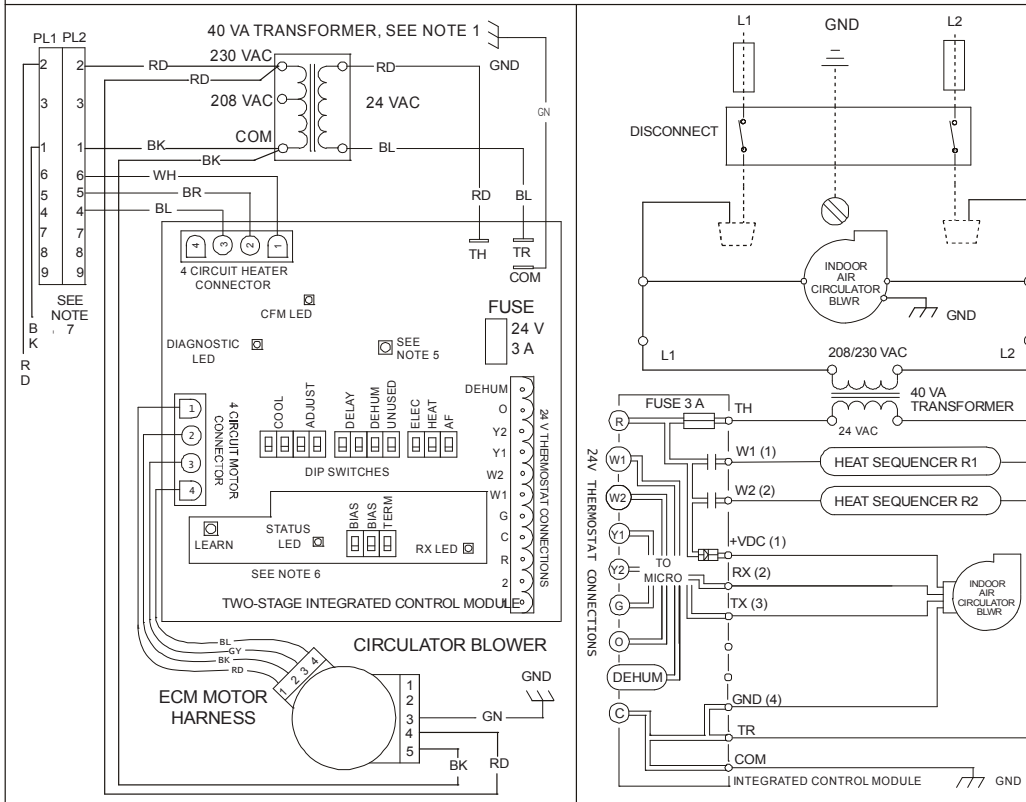

- NOTES:
- PLACE RED WIRE ON TRANSFORMER TERMINAL 2 FOR 208 VAC OPERATION.
 - MANUFACTURER'S SPECIFIED REPLACEMENT PARTS MUST BE USED WHEN SERVICING.
 - IF ANY OF THE ORIGINAL WIRE AS SUPPLIED WITH THE BLOWER MUST BE REPLACED, IT MUST BE REPLACED WITH WIRING MATERIAL HAVING A TEMPERATURE RATING OF AT LEAST 105°C. USE COPPER CONDUCTORS ONLY.
 - UNIT MUST BE PERMANENTLY GROUNDED AND CONFORM TO N.E.C. AND LOCAL CODES.
 - TO RECALL THE LAST 6 FAULTS, MOST RECENT TO LEAST RECENT, DEPRESS SWITCH FOR MORE THAN 2 SECONDS WHILE IN STANDBY (N THERMOSTAT INPUTS).
 - BIAS AND TERM DIPSWITCHES MUST BE IN "ON" POSITION. RED STATUS LED PROVIDES NETWORK STATUS. GREEN RX LED INDICATES NETWORK TRAFFIC. USE LEARN BUTTON TO RESET NETWORK.
 - DISCARD CONNECTOR PL1 WHEN INSTALLING OPTIONAL HEAT KIT.

0140A00039 REV. A

- COLOR CODES:
- PK PINK
 - BR BROWN
 - WH WHITE
 - BL BLUE
 - GY GRAY
 - RD RED
 - YL YELLOW
 - OR ORANGE
 - VT VIOLET
 - GN GREEN
 - BK BLACK

- LOW VOLTAGE (24V) ———
- LOW VOLTAGE FIELD - - - - -
- HI VOLTAGE (230V) ———
- HI VOLTAGE FIELD - - - - -
- JUNCTION ●
- TERMINAL ○
- INTERNAL TO INTEGRATED CONTROL ———
- EQUIPMENT GND ⚡
- FIELD GND ⊥
- FIELD SPLICE ⏏
- RESISTER ⏚
- OVERCURRENT PROT. DEVICE ⏚
- PLUG CONNECTION ⏚

High Voltage: Disconnect all power before servicing or installing this unit. Multiple power sources may be present. Failure to do so may cause property damage, personal injury, or death.

WARNING

Wiring is subject to change. Always refer to the wiring diagram or the unit for the most up-to-date wiring.

NOTES



Goodman Manufacturing Company, L.P., reserves the right to discontinue, or change at any time, specifications or designs without notice or without incurring obligations. © 2010 • Goodman Manufacturing Company, L.P. • Houston, Texas • Printed in the USA.

