



Air Conditioning & Heating

# HRV/ERV SERIES

## HEAT RECOVERY AND ENERGY RECOVERY VENTILATORS

### Standard Features

- Energy-efficient, aluminum HRV core and enthalpy ERV core are configured for efficient cross-flow ventilation and designed to withstand extreme temperature variations (HRV-300D has 2 cores)
- Two German-manufactured, factory-balanced EBM™ external rotor motors with backward-curved blades
- Permanently lubricated, sealed motor bearings
- Two washable, electrostatic, panel-type air filters
- External, three-position rocker switch for continuous ventilation
- State-of-the-art control boards provide easy connection to existing HVAC equipment
- Easy-access door, service light indicator, and external electrical box make service and maintenance simple
- Screw-type dial on electrical box allows supply air to be adjusted to match exhaust airflow and uses the “true” motor adjustment feature (HRV-150D, HRV-200D only)
- Advanced Defrost Cycle (HRV Series)

### Cabinet Features

- Fully insulated cabinet with 1” high-density, polystyrene foam insulation meets the requirements of the UL 94 HF
- 22-gauge galvanized-steel cabinet with powder-coat paint finish; HRV-150 and HRV-150D are 24-gauge
- Unit may be installed using the factory-supplied installation kit



\* Complete warranty details available from your local dealer or at [www.goodmanmfg.com](http://www.goodmanmfg.com).



# SPECIFICATIONS

Model	Recovery Ventilator Type	CFM	Power*				Core Size	Filter Sizes	Weight (lbs)
			Volts	Hz	Amps	Watts			
HRV-150	Heat	123	120	60	1.5	150	9" x 9" x 15"	8.5" x 15" x 0.125"	49
HRV-200	Heat	168	120	60	1.9	150	12" x 12" x 15"	11.75" x 15" x 0.125"	66
HRV-150D	Heat w Recirculation	123	120	60	1.5	150	9" x 9" x 15"	8.5" x 15" x 0.125"	51
HRV-200D	Heat w/ Recirculation	168	120	60	1.9	150	12" x 12" x 15"	11.75" x 15" x 0.125"	66
HRV-300D	Heat w/ Recirculation	247	120	60	2.7	150	12" x 12" x 15"	11.75" x 15" x 0.125"	125
ERV-150	Energy	135	120	60	1.5	150	9" x 9" x 15"	8.5" x 15" x 0.125"	49
ERV-200	Energy	155	120	60	1.9	150	12" x 12" x 15"	11.75" x 15" x 0.125"	66

\* All units come with a 3' plug-in power cord with 3-prong plug

# PERFORMANCE DATA

Model	Apparent Sensible Effectiveness at 32°F (0°C)	Apparent Sensible Effectiveness at -13°F (-25°C)
HRV-150/HRV-150D	72%	69%
HRV-200/HRV-200D	71%	76%
HRV-300D	92%	91%
ERV-150	72%	69%
ERV-200	71%	76%

NOTE: Airflow Cap. CFM (L/A) @ 0.4 on High Speed

## HRV PERFORMANCE CHARTS

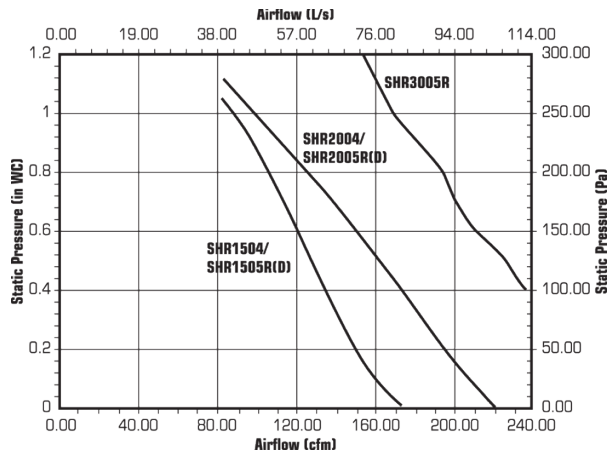

## ERV PERFORMANCE CHARTS

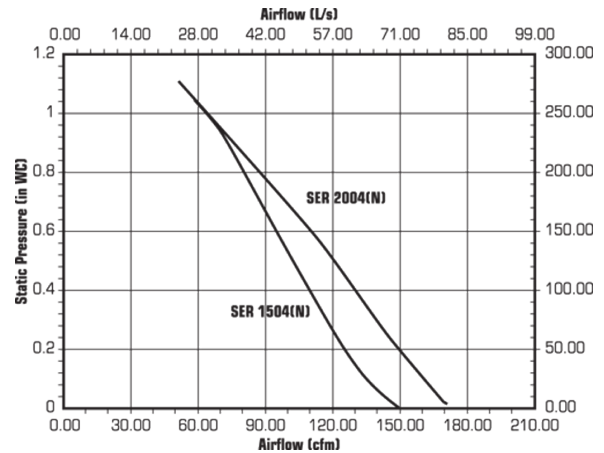

## HRV AND ERV DIMENSIONS

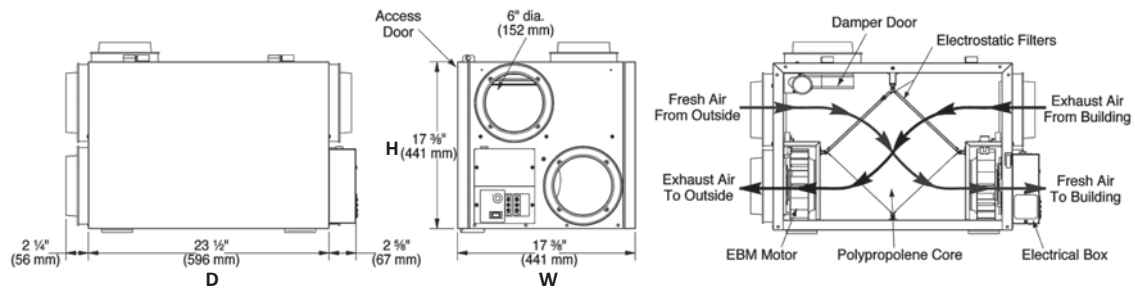

Model	Dimensions					
	Width	Depth	Height	Supply/ Exhaust Diameter	External Vent Depth	Internal Vent Depth
HRV-150	17 $\frac{3}{8}$ "	23 $\frac{1}{2}$ "	16 $\frac{1}{8}$ "	6"	2 $\frac{1}{4}$ "	2 $\frac{5}{8}$ "
HRV-200	17 $\frac{3}{8}$ "	27 $\frac{7}{8}$ "	20 $\frac{1}{2}$ "	6"	2 $\frac{1}{4}$ "	2 $\frac{5}{8}$ "
ERV-150	17 $\frac{3}{8}$ "	23 $\frac{1}{2}$ "	16 $\frac{1}{8}$ "	6"	2 $\frac{1}{4}$ "	2 $\frac{5}{8}$ "
ERV-200	17 $\frac{3}{8}$ "	27 $\frac{7}{8}$ "	20 $\frac{1}{2}$ "	6"	2 $\frac{1}{4}$ "	2 $\frac{5}{8}$ "

## HRV WITH RECIRCULATION DIMENSIONS

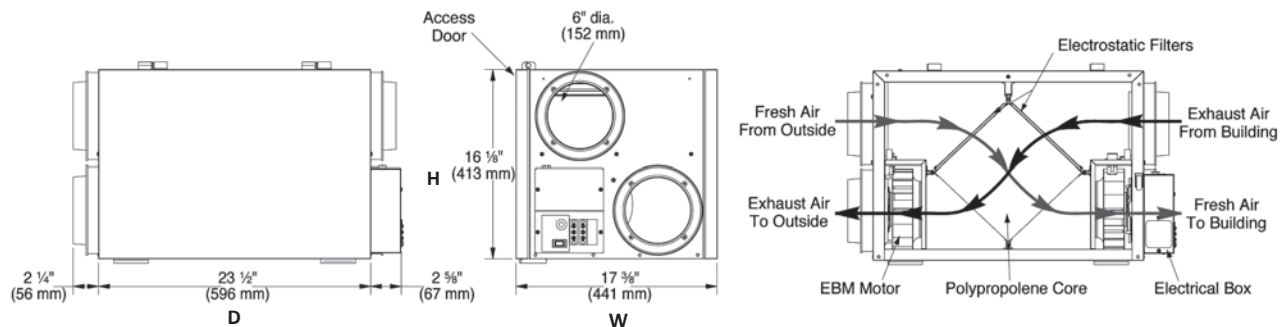

Model	Dimensions					
	Width	Depth	Height	Supply/ Exhaust Diameter	External Vent Depth	Internal Vent Depth
HRV-150D	17 $\frac{3}{8}$ "	23 $\frac{1}{2}$ "	17 $\frac{3}{8}$ "	6"	2 $\frac{1}{4}$ "	2 $\frac{5}{8}$ "
HRV-200D	17 $\frac{3}{8}$ "	27 $\frac{7}{8}$ "	20 $\frac{1}{2}$ "	6"	2 $\frac{1}{4}$ "	2 $\frac{5}{8}$ "
HRV-300D	17 $\frac{3}{8}$ "	50 $\frac{5}{8}$ "	22 $\frac{1}{5}$ "	6"	2 $\frac{1}{4}$ "	2 $\frac{1}{4}$ "

## ACCESSORIES

### OPTIONAL REMOTE CONTROLS

Model	Description
DMFC	Digital Multi-Function Wall Control
DMFC-REC	Digital Multi-Function Wall Control with Recirculation
MD-2W	2-Wire, Low-Voltage Mechanical Dehumidistat
MD-4W	4-Wire, Low-Voltage Mechanical Dehumidistat with On/Off switch
RT-15M	15-minute push-button timer
CT-30M	30-minute crank timer
AQS	Air quality sensor

### EXHAUST HOODS

Model	Description
SEH-6M	Metal Supply & Exhaust Hoods (6")
SEH-6P	Plastic Supply & Exhaust Hoods (6")

